



FritsJurgens[®]

SYSTEM M
MILLING AND MOUNTING MANUAL

 **better** BUILDING HARDWARE

BUY NOW : +1-888-636-1627

BOX CONTENTS

COMPONENTS

- 1.1 Ceiling plate - Class B
- 1.2 Ceiling plate - Class G
- 1.3 Ceiling plate - Cable Grommet
- 2.1 Top pivot 40 mm - Class B or G
- 2.2 Top pivot 70 mm - Class B or G
- 2.3 Top pivot Cable Grommet
- 3.1 Bottom pivot System M 40 mm - Class AA to C or Bottom pivot System M+ 40 mm - Class A to E
- 3.2 Bottom pivot System M 70 mm - Class AA to C or Bottom pivot System M+ 70 mm - Class A to E
- 3.3 Bottom pivot System M+ 40 mm - Class F and G
- 3.4 Bottom pivot System M+ 70 mm - Class F and G
- 4.1 Floor plate System M - Squared
- 4.2 Floor plate System M - Round
- 4.3 Floor plate System M - Flush squared
- 4.4 Floor plate System M - Flush rounded

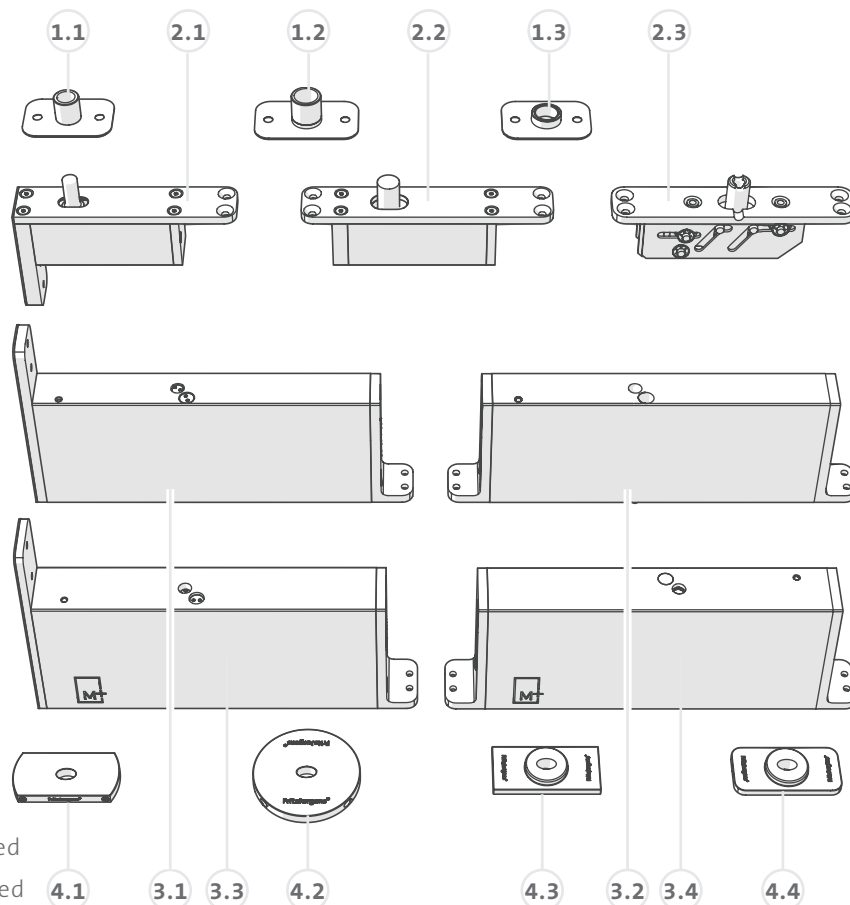

MILLING AND MOUNTING KIT

- 5.1 Torx bit TX20 (1x)
- 5.2 Screws (4x50) (10x)
- 5.3 Fitting adhesive
- 5.4 Allen key 5
- 5.5 Allen key 3
- 5.6 Mounting pins, short* (2x)
- 5.7 Mounting pins, long* (2x)
- 5.8 Fitting template
- 5.9 Double-sided fine-tuning sheet**
- 5.10 Adjustment spanner

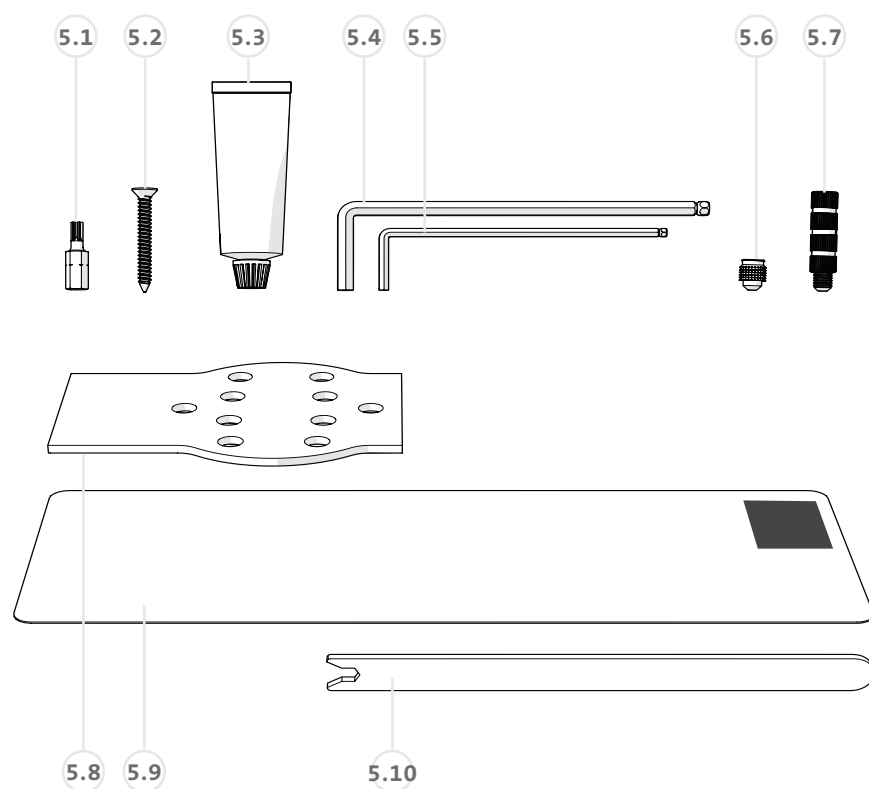

* Only in box floor plate System M - Squared

** Only for M+

SYSTEM OVERVIEW

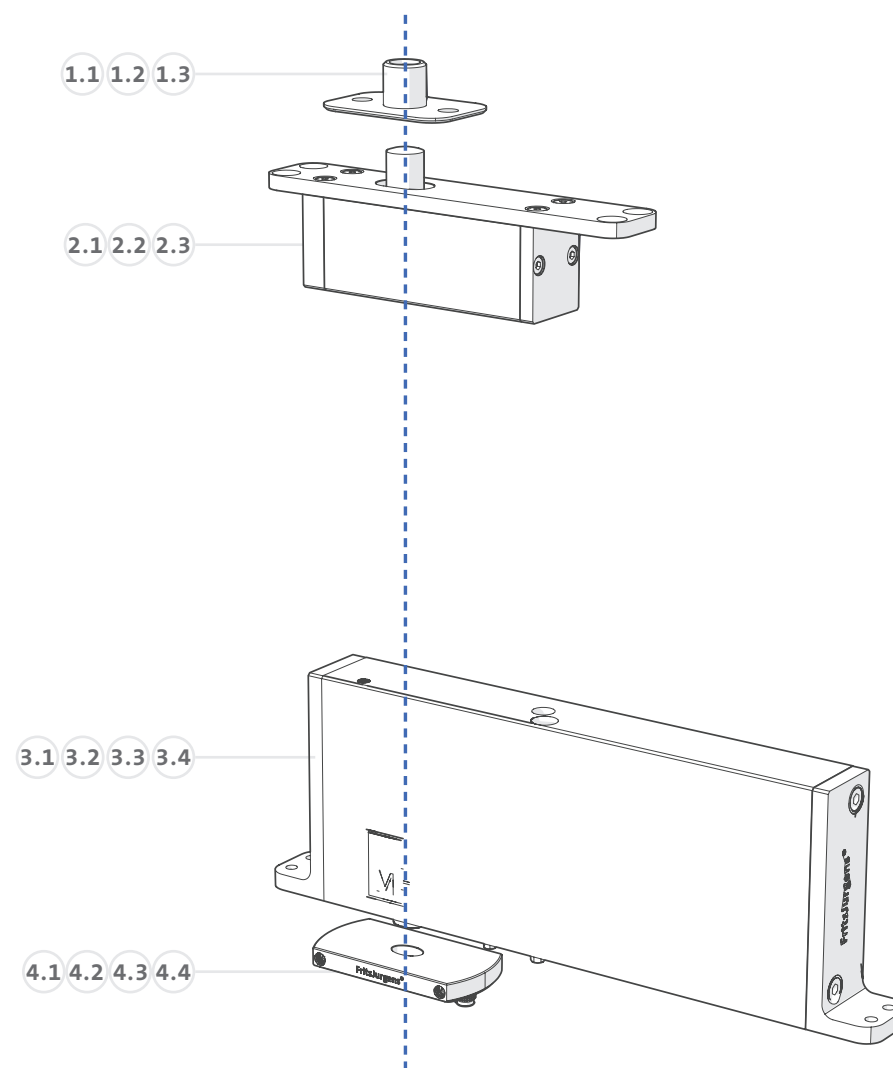

MILLING INSTRUCTIONS

→ Determine pivot point A.

System M+/M - Class AA to E

- A = 40 mm → page 4
- $70 \text{ mm} \leq A < 250 \text{ mm}$ → page 6
- A > 250 mm → page 12

System M+/M - Class F and G

- A = 40 mm → page 8
- $70 \text{ mm} \leq A < 250 \text{ mm}$ → page 10
- A > 250 mm → page 12

Top pivot Cable Grommet

→ page 14

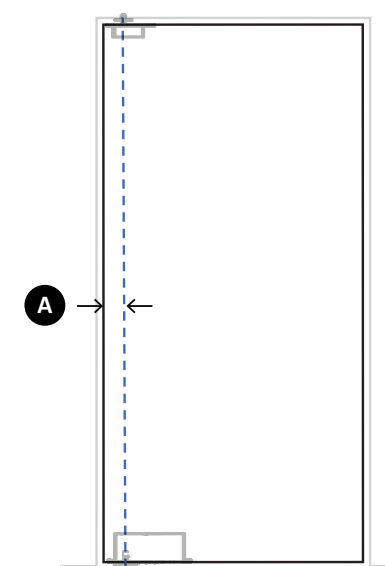

MOUNTING INSTRUCTIONS

→ page 15

A = 40 MM
PREPARING THE DOOR

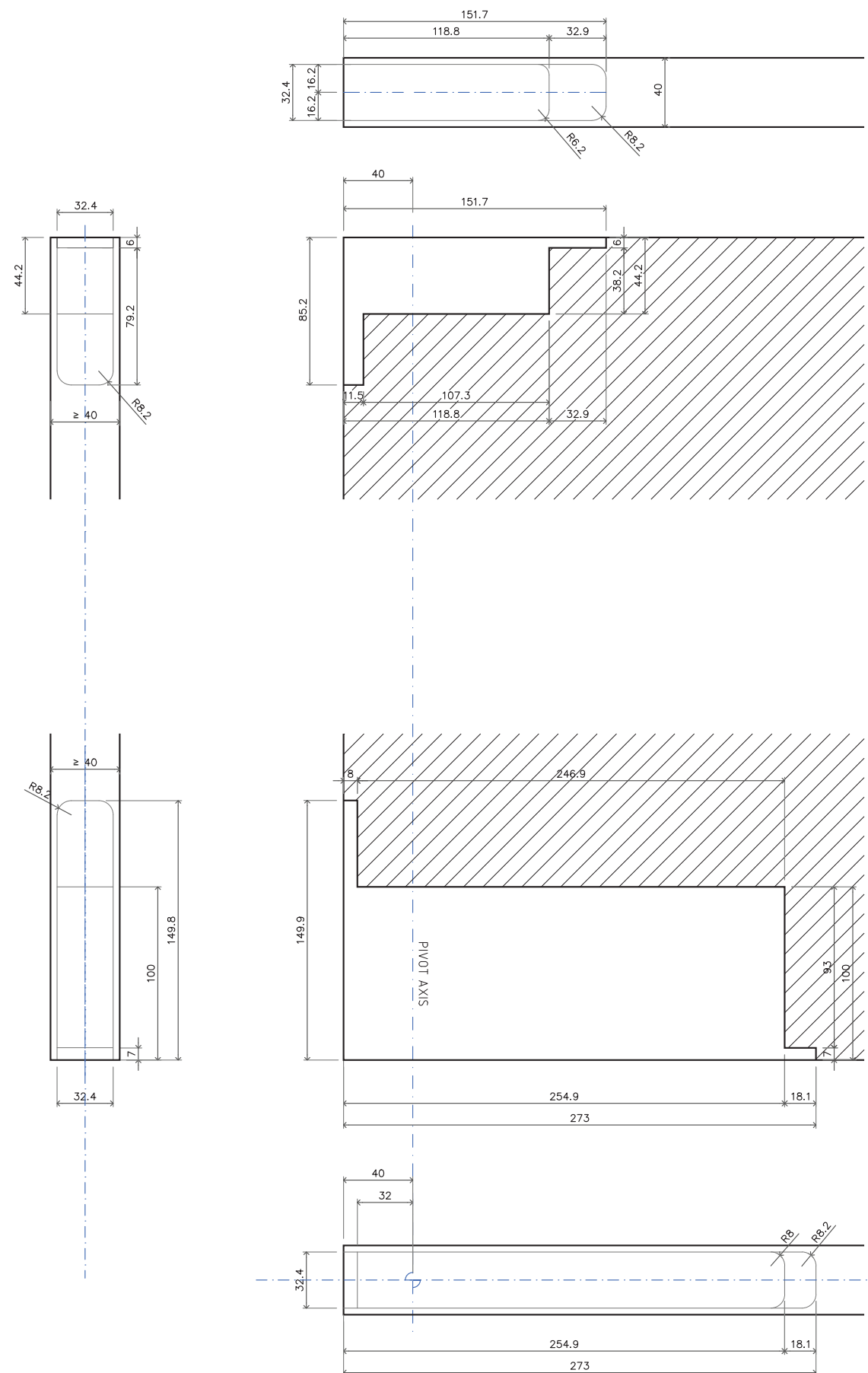

COMPONENTS

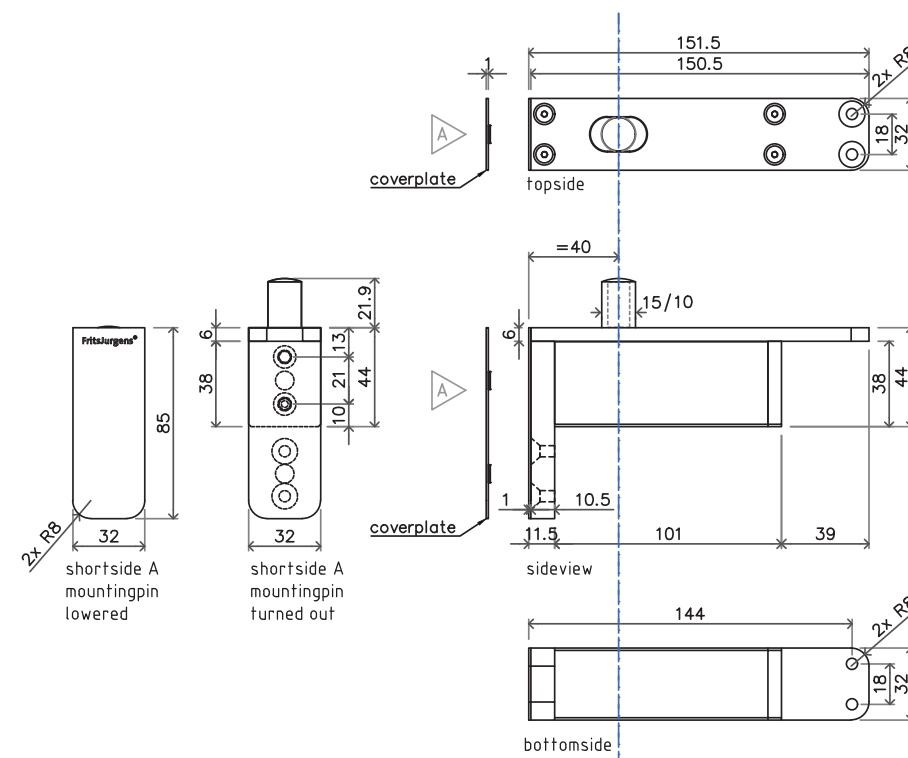

www.fritsjurgens.com/installation-tp40

Top pivot 40 mm - Class B or G

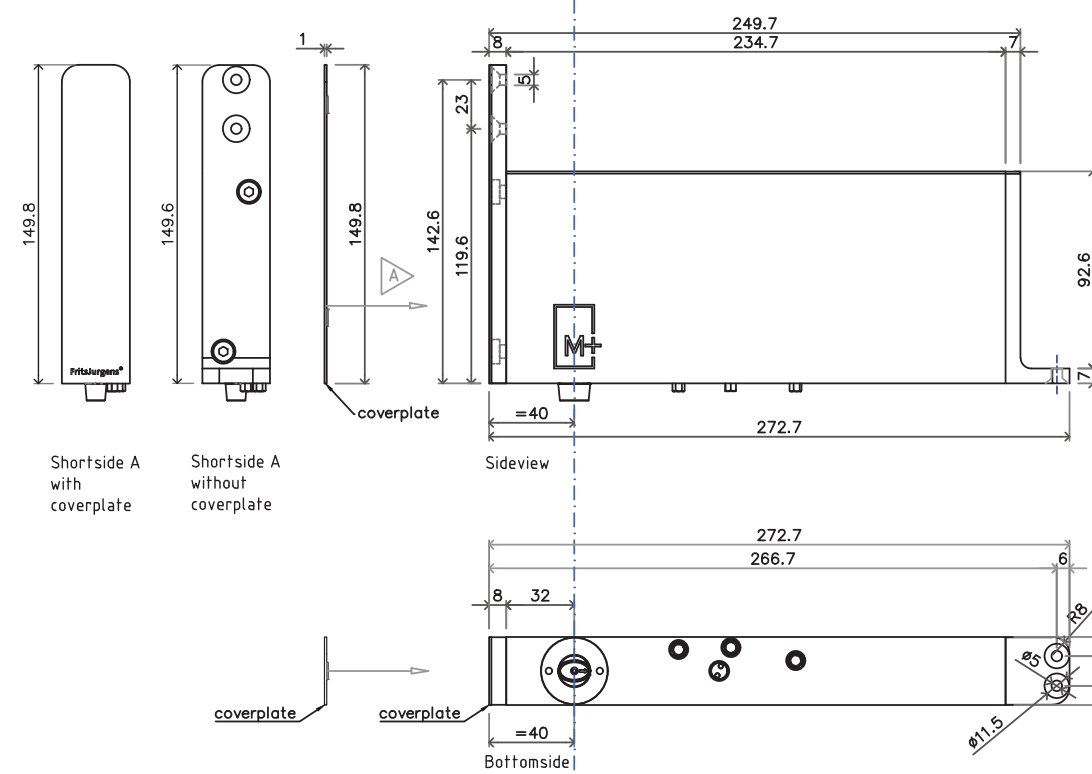

System M 40 mm
System M+ 40 mm

A = 40 MM
PREPARING THE DOOR

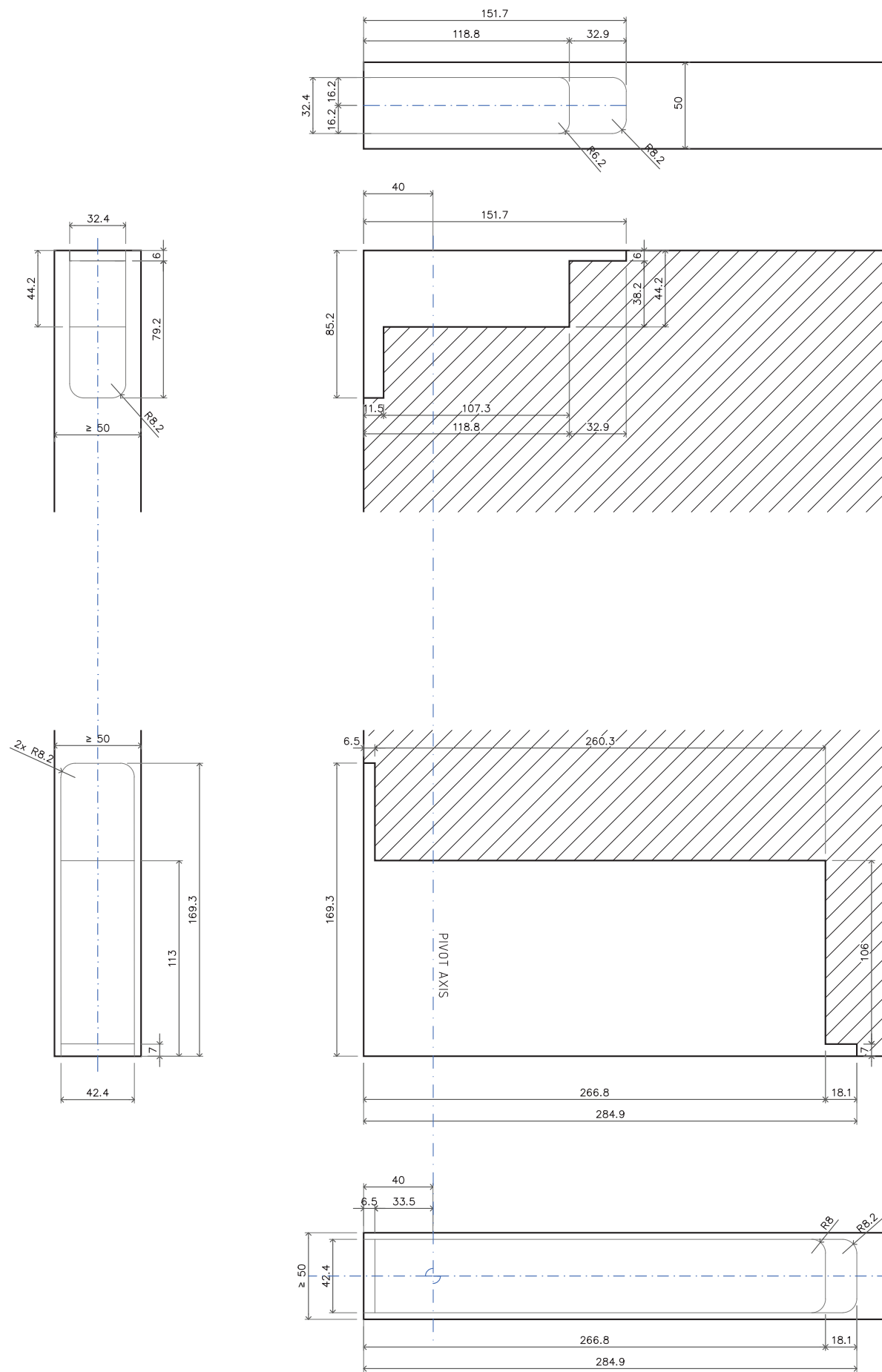

COMPONENTS

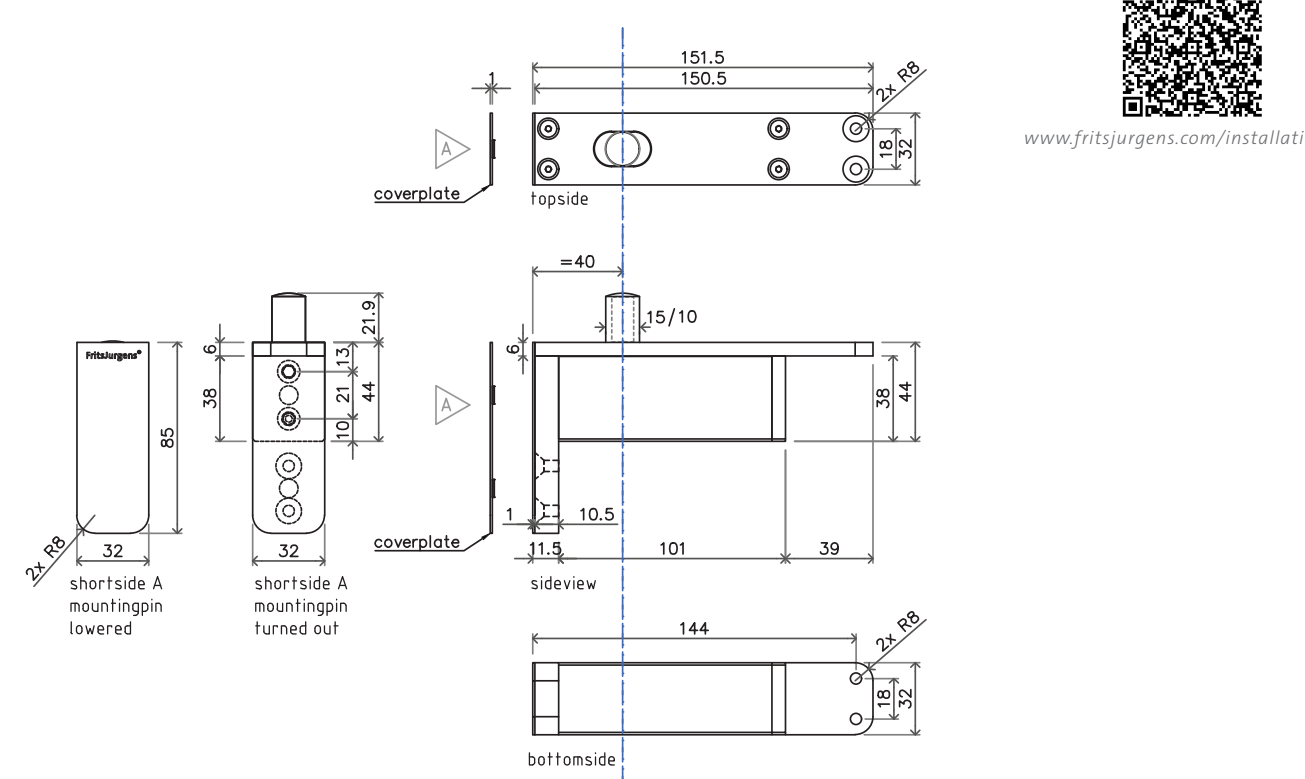

Top pivot 40 mm - Class B or G

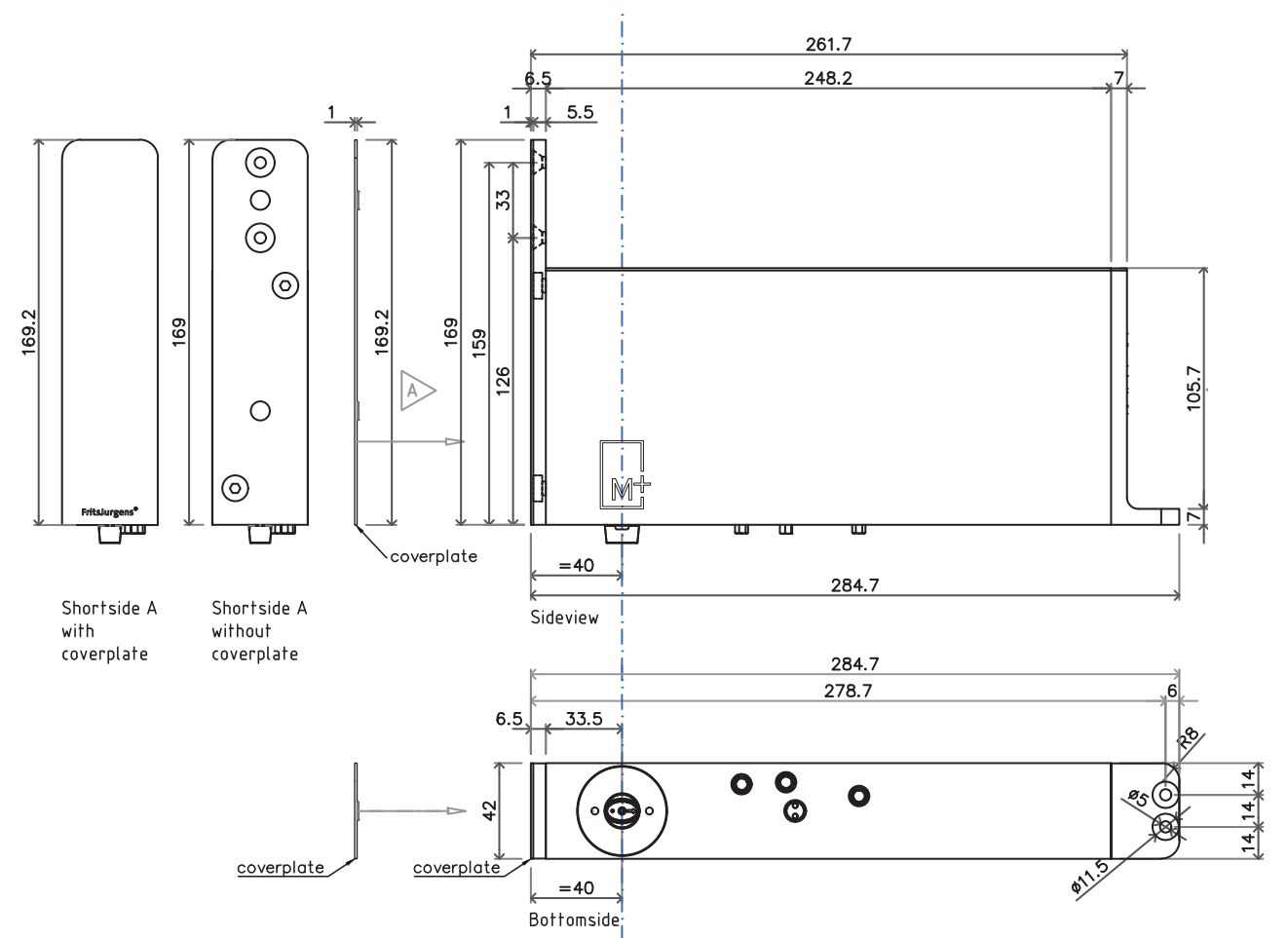

System M+ 40 mm - Class F and G

70MM ≤ A < 250 MM
PREPARING THE DOOR

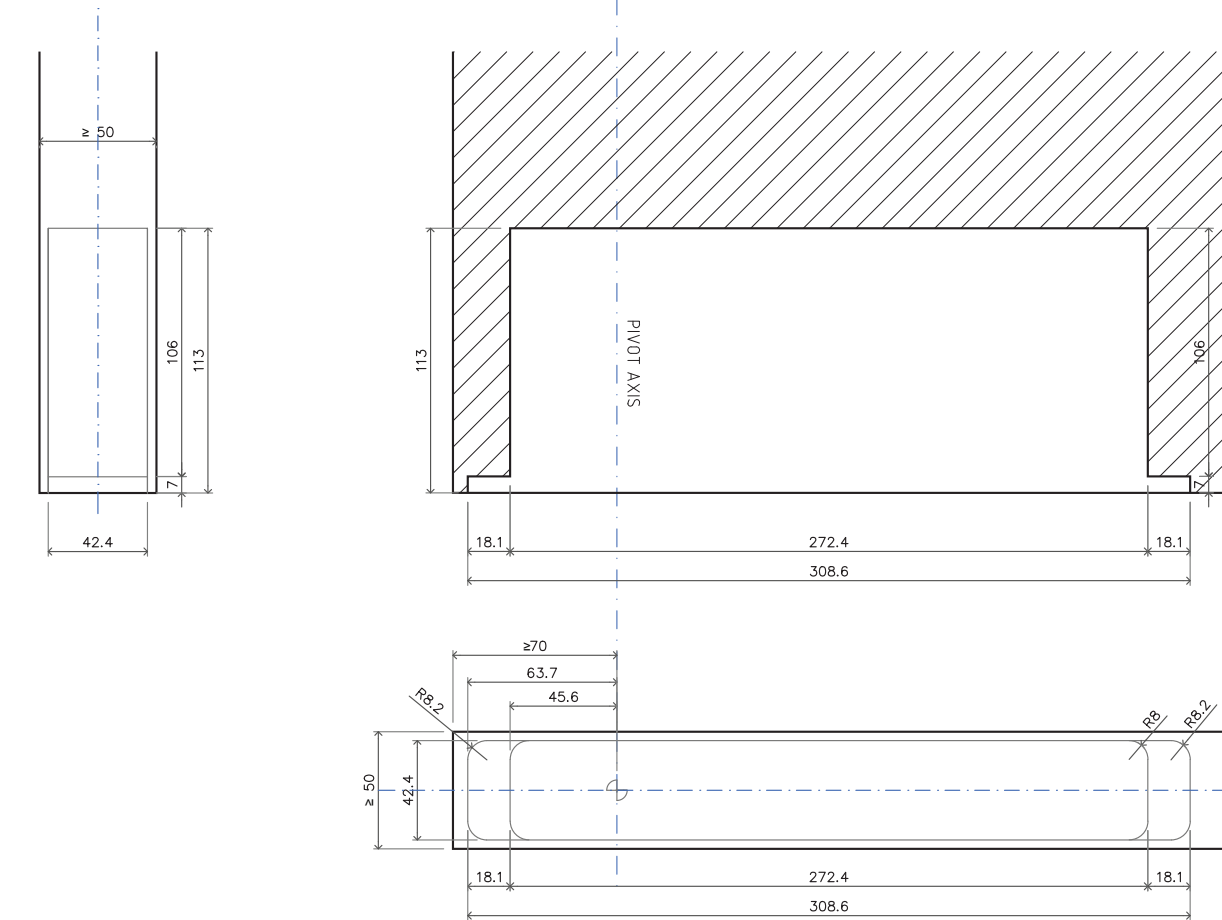
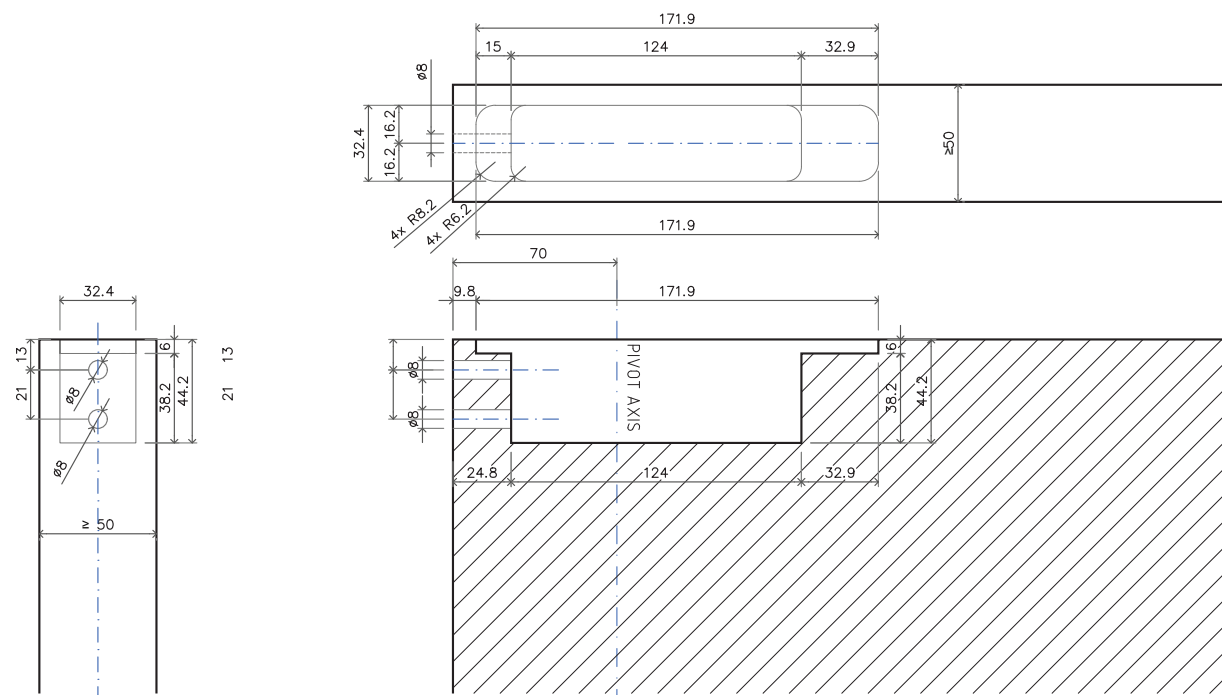

COMPONENTS

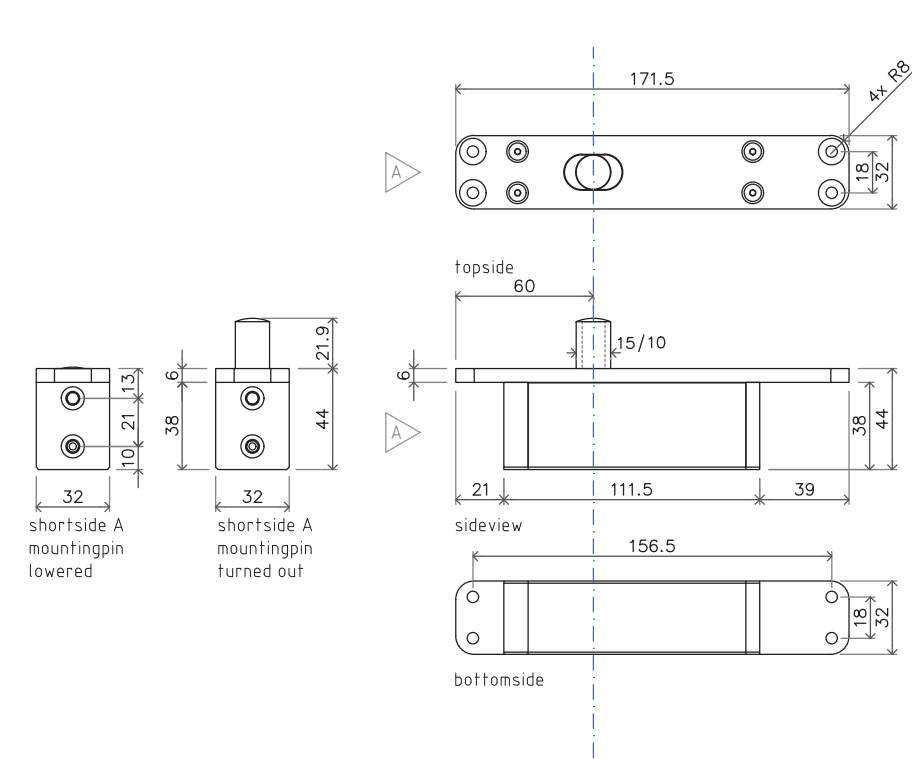

Top pivot 70 mm - Class B or G

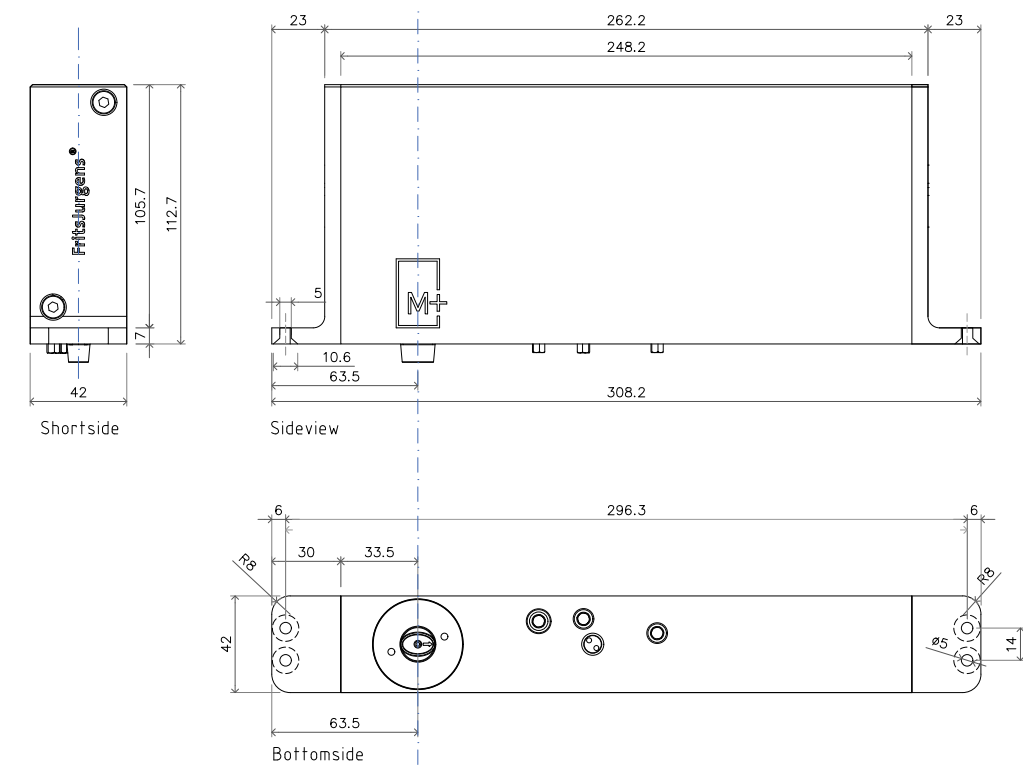

System M+ 70 mm - Class F and G

FLOOR PLATE SQUARE, FLOOR PLATE ROUND

1 Determine the position of pivot point **A** on the floor. Use the fitting template and the table below.

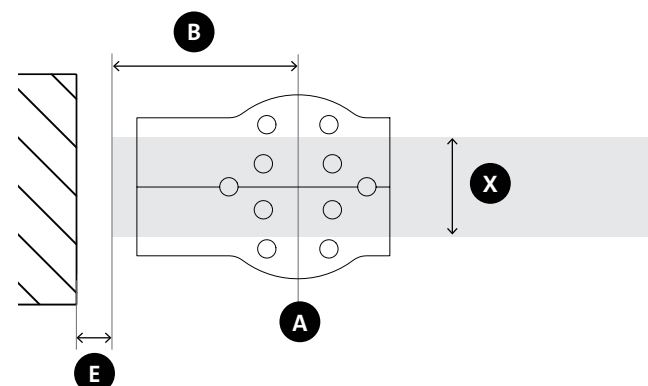

| | 40 | 50 | 60 | 70 | 80 | 90 | 100 | X |
|------|----|----|----|----|----|----|-----|---|
| B | | | | | | | | |
| 40 | 7 | 9 | 12 | 15 | 19 | 22 | 26 | |
| 70 | 5 | 6 | 10 | 10 | 13 | 15 | 18 | |
| 91 | 4 | 5 | 7 | 9 | 10 | 12 | 15 | |
| 250 | 3 | 3 | 4 | 4 | 5 | 6 | 7 | |
| 500 | 2 | 3 | 3 | 3 | 4 | 4 | 5 | |
| 1000 | 2 | 2 | 3 | 3 | 3 | 3 | 3 | |
| 1500 | 2 | 2 | 2 | 2 | 2 | 3 | 3 | |
| 2000 | 2 | 2 | 2 | 2 | 2 | 2 | 3 | E |

E Minimum gap between door and wall (mm)

B Distance pivot point to door edge (mm)

X Door thickness (mm)

2 Mark pivot point **A** on the floor and on the ceiling.

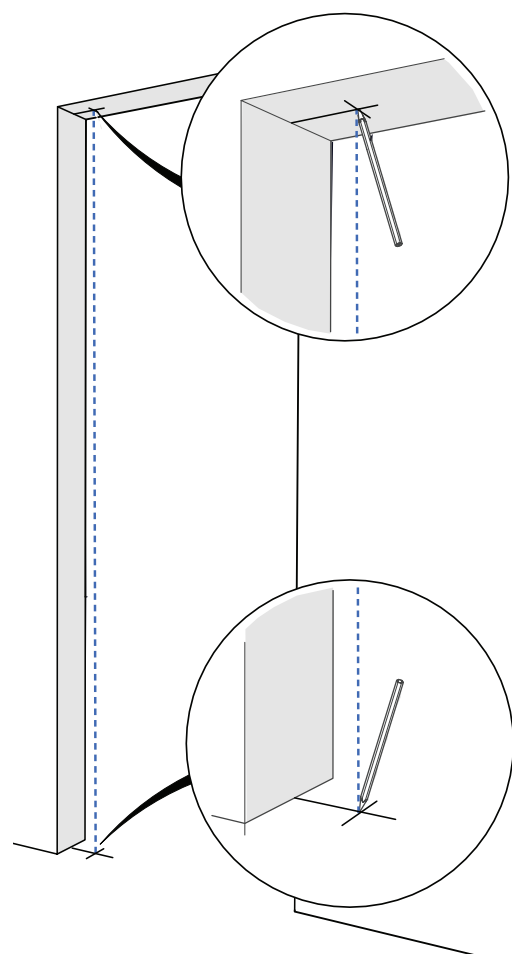

3 Mark the drilling holes on the floor. Use the fitting template.

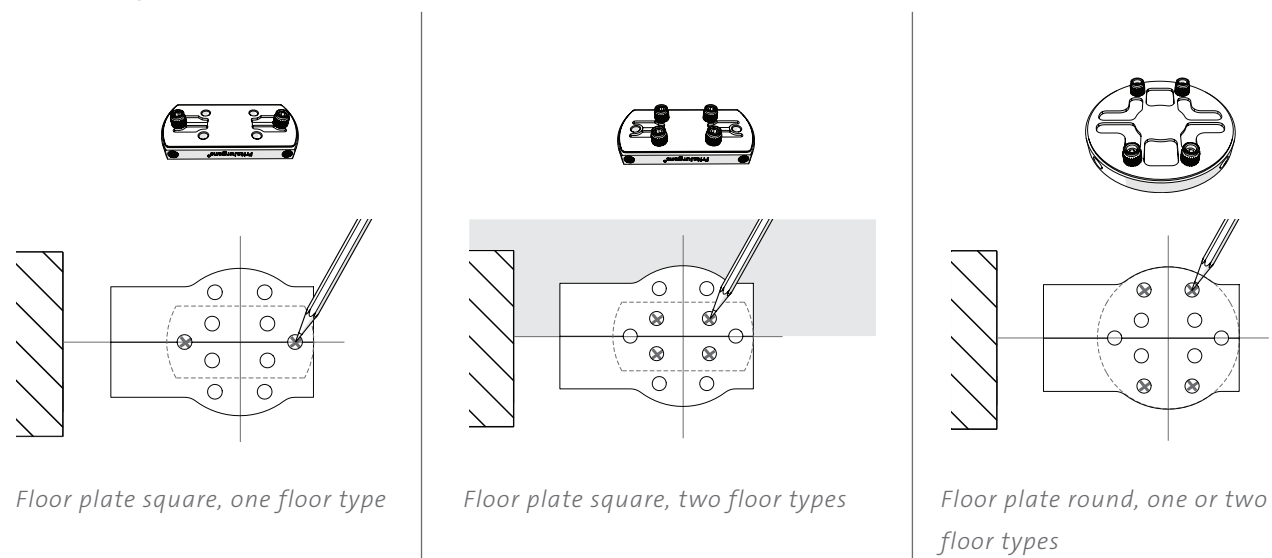

Floor plate square, one floor type

Floor plate square, two floor types

Floor plate round, one or two floor types

4 Select the correct drill bit for the floor and determine the drilling depth.

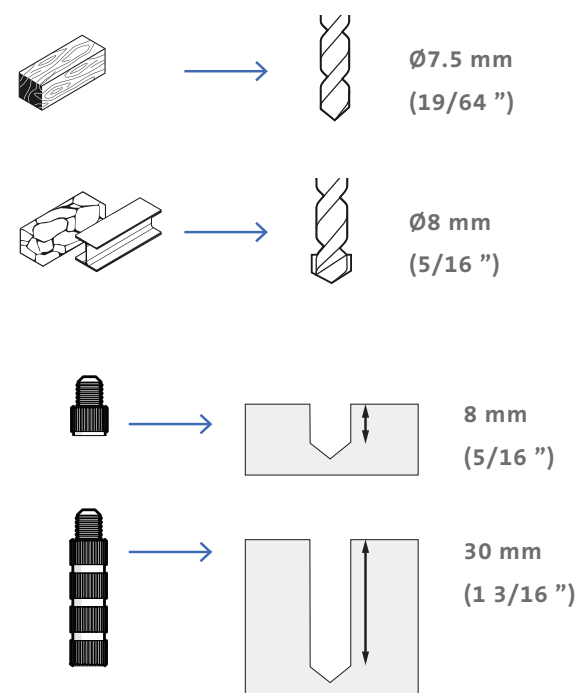

5 Drill the holes in the floor on the marked spots.

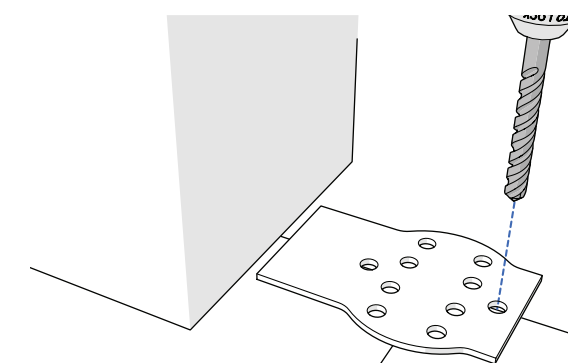

6 Determine the pin configuration for your situation. If necessary, use Allen key 3 to unmount the pre-installed pins and install the correct configuration.

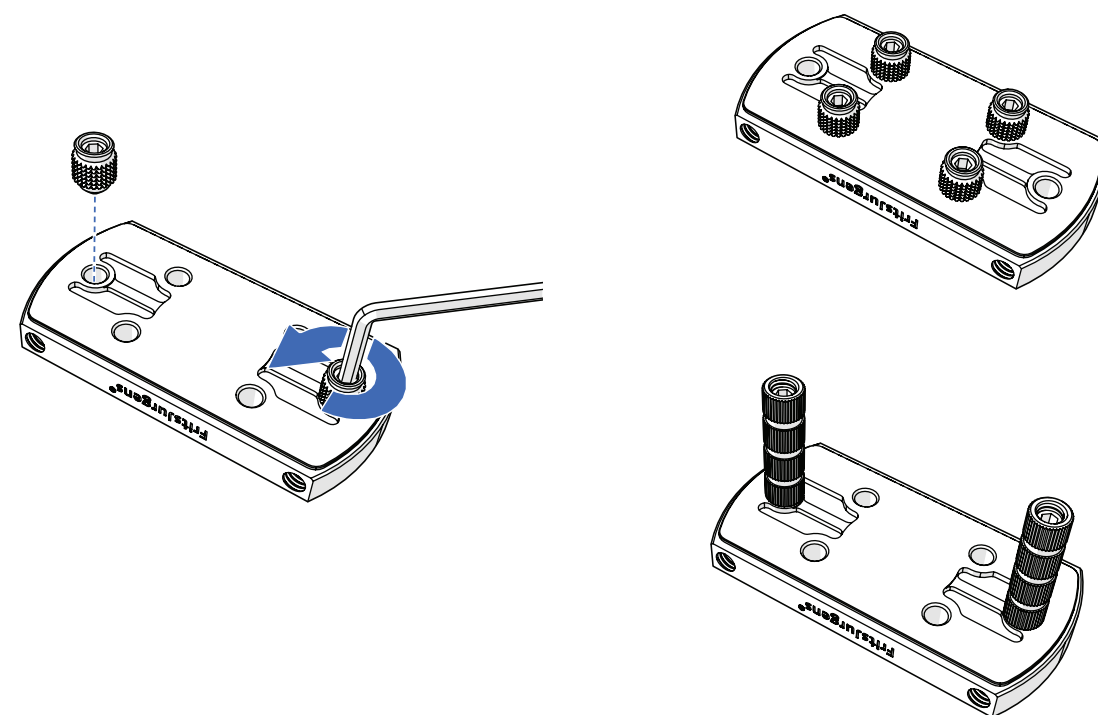

7 Fill the glue chambers in the floor plate with glue and apply a 1 mm layer of glue in between the chambers.

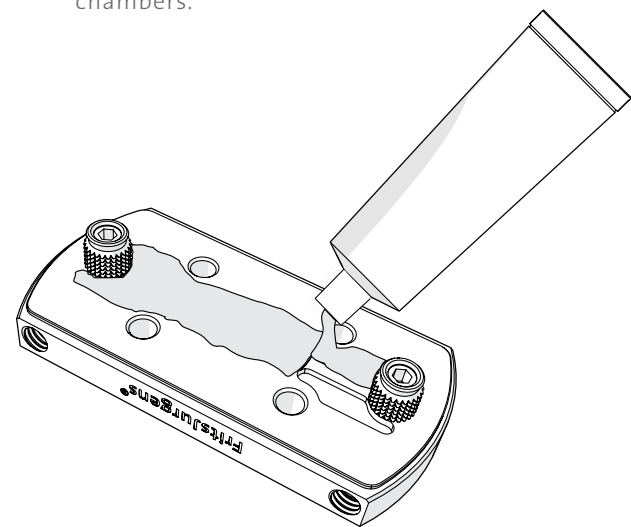

8 Add glue in the holes in the floor. Make sure the holes don't overflow when you place the floor plate.

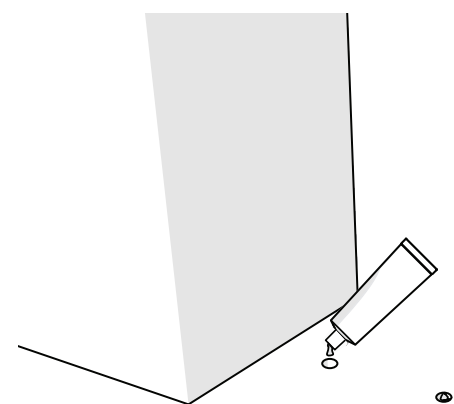

9 Use a rubber hammer to affix the floor plate.

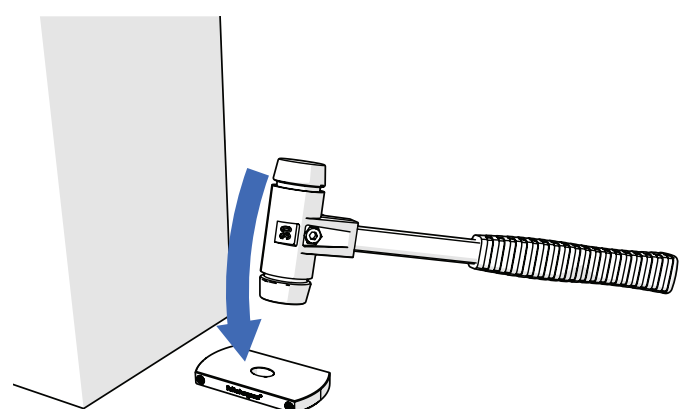
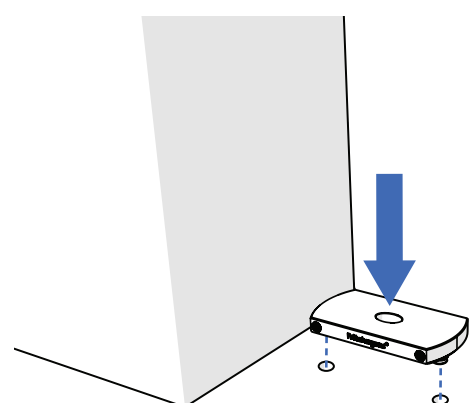

FLOOR PLATE FLUSH ROUNDED
PREPARING THE FLOOR

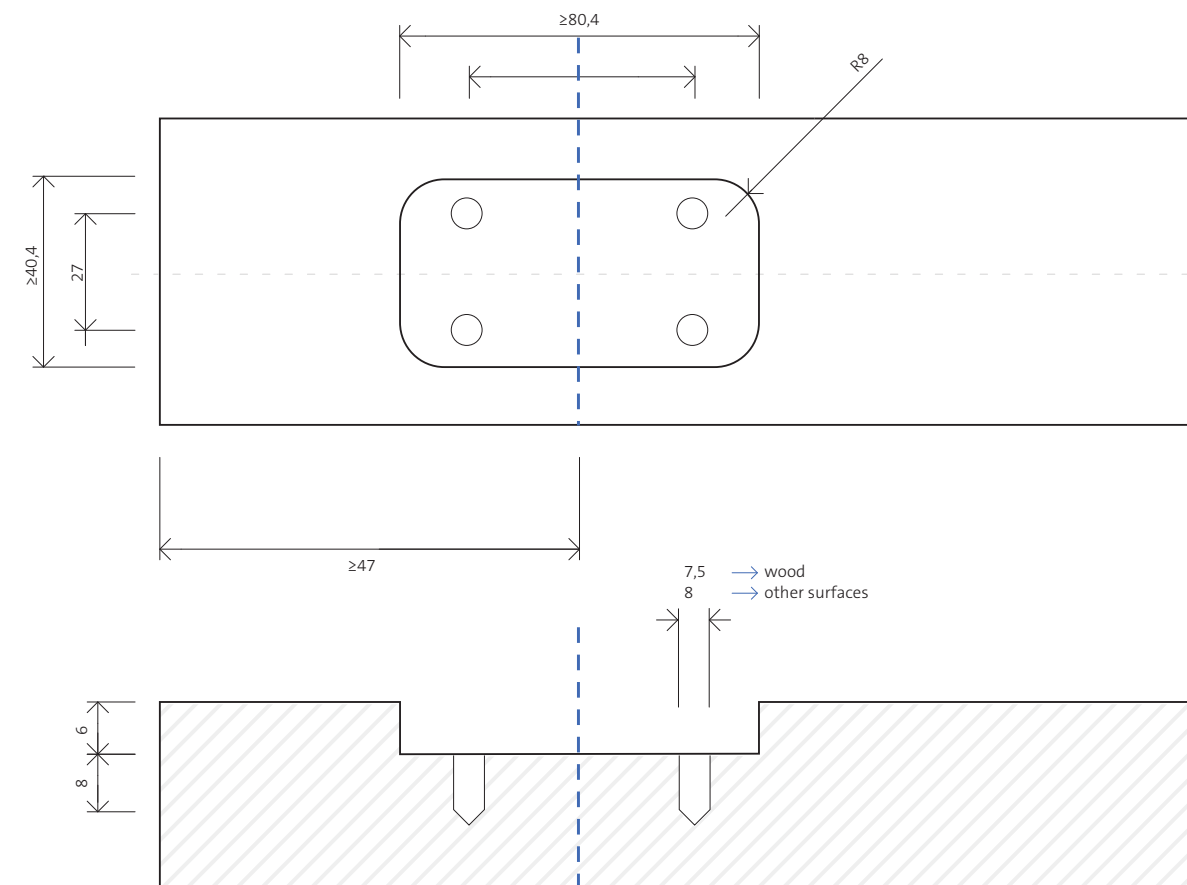

DIMENSIONS

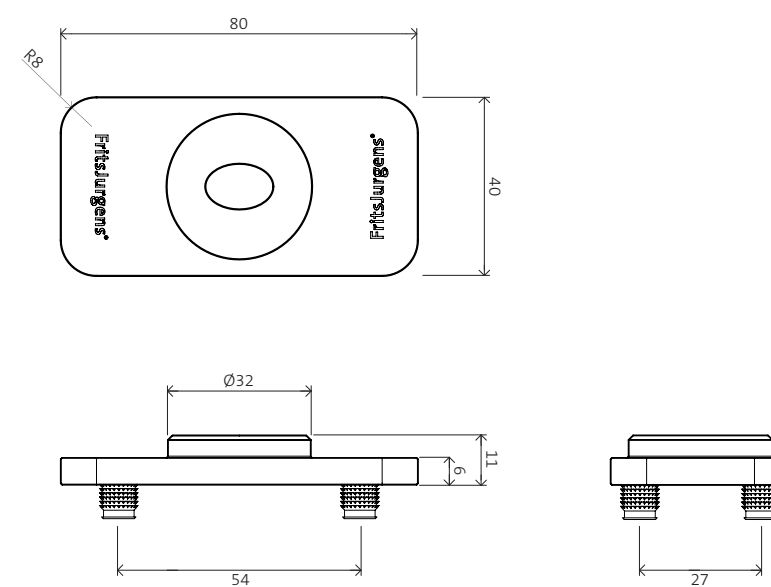

→ continue on page 21

→ follow steps 7, 8 and 9 on page 18

FLOOR PLATE FLUSH SQUARE
PREPARING THE FLOOR

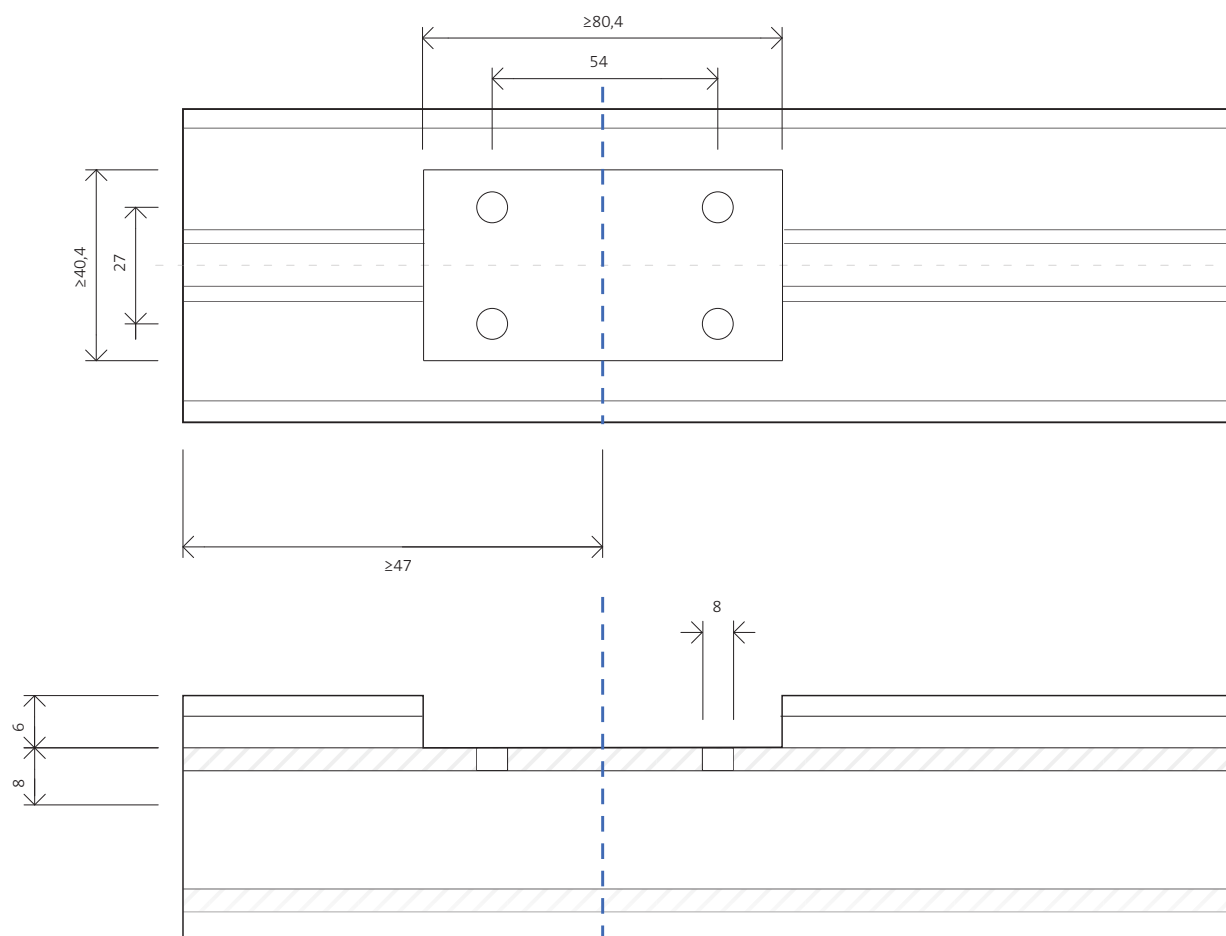

DIMENSIONS

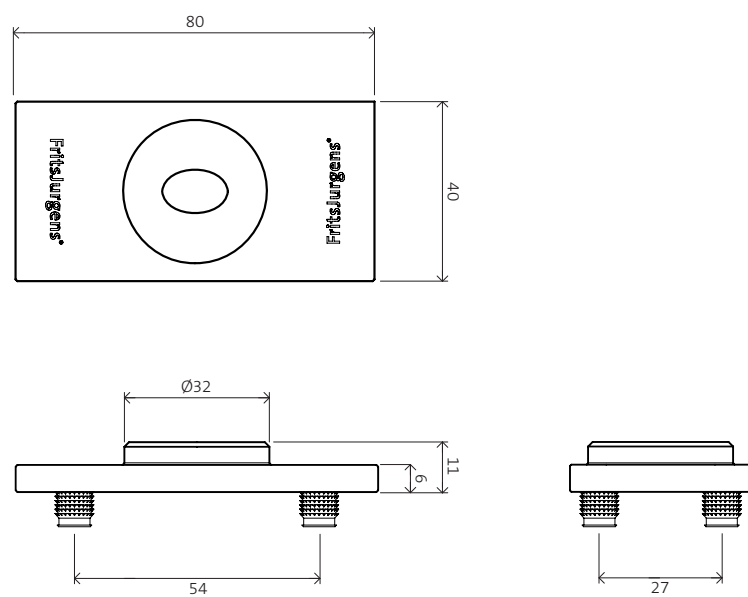

→ follow steps 7, 8 and 9 on page 18

CEILING PLATE

1 Drill a hole for the ceiling plate.

- ceiling plate 20 mm $\text{Ø}18$ mm
10 mm (25/32 ") (45/64 ")
- ceiling plate 20 mm $\text{Ø}20$ mm
15 mm (25/32 ") (25/32 ")
- ceiling plate $\text{Ø}18$ mm
cable (45/64 ")
grommet

2 Apply a 1 mm thick layer of glue to the ceiling plate.

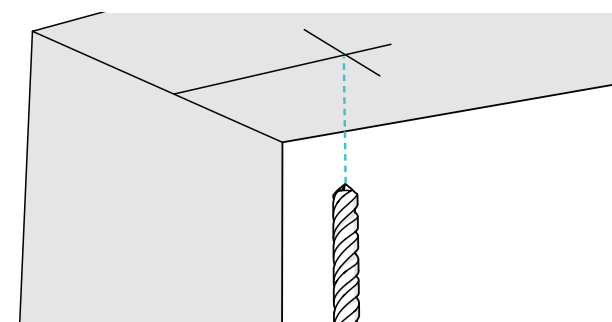
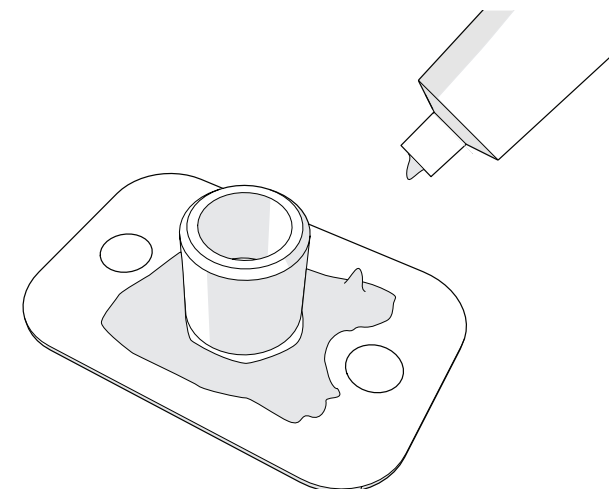

3 Affix the ceiling plate.

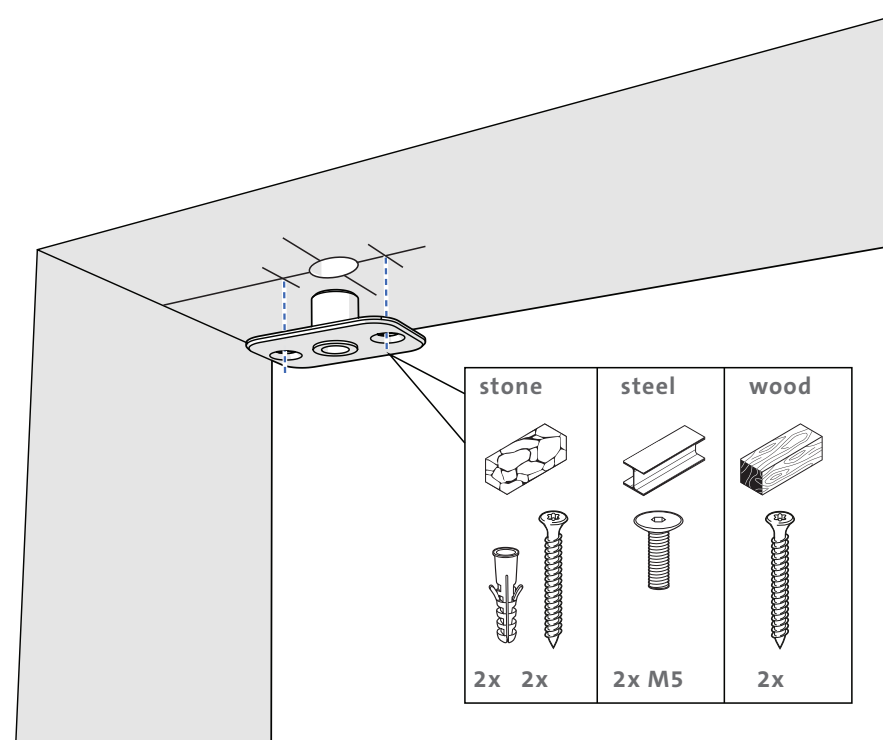

DOOR

- 1 Determine in which direction you will install the door. Turn the arrow on the system's spindle so it points to the latch side of the door when you install it. You can do this with the axle wrench or floor plate.

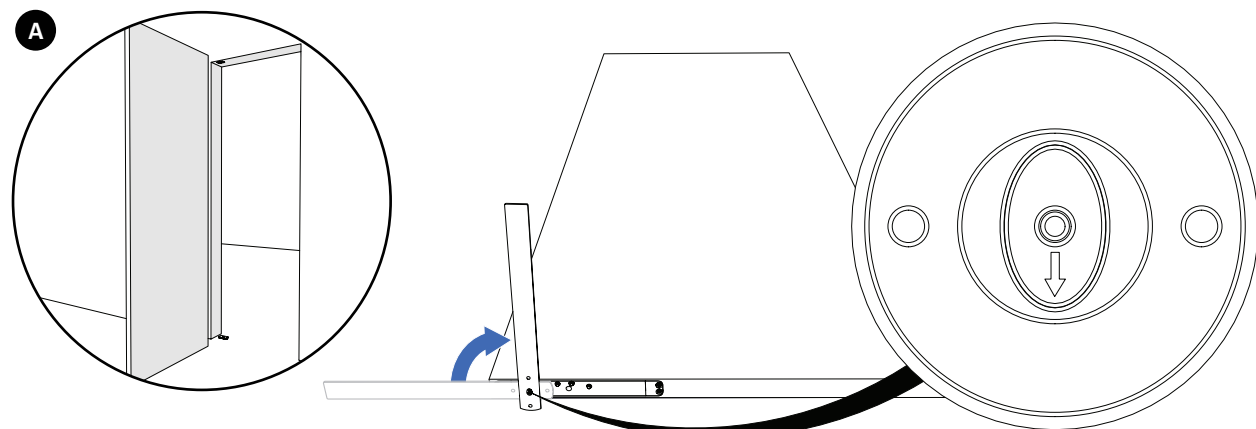

PAY ATTENTION

If you need to take the door out of the floor plate during the mounting process, always put it back the same way. If you do not do that, the arrow will point in the wrong direction, and the system will not function correctly.

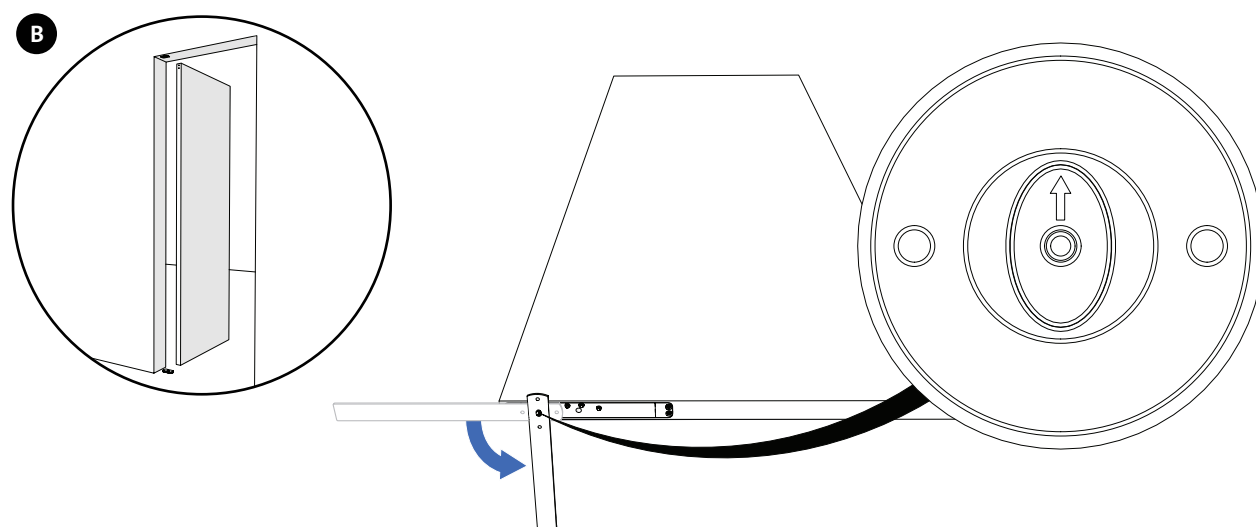
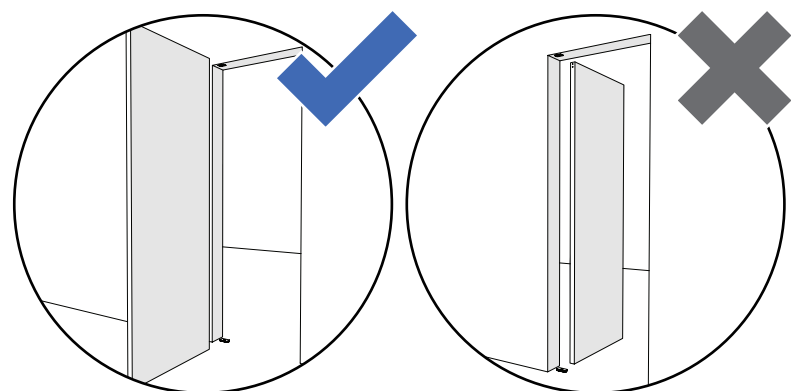

PAY ATTENTION

If you need to take the door out of the floor plate during the mounting process, always put it back the same way. If you do not do that, the arrow will point in the wrong direction, and the system will not function correctly.

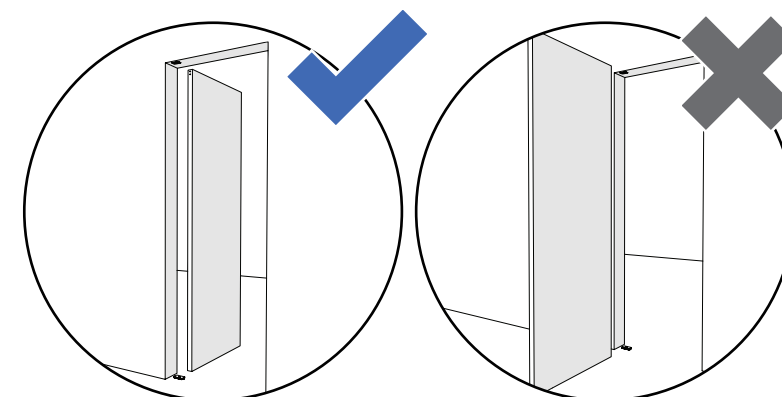

- 2 Position the door on the floor plate and align it with the ceiling plate.

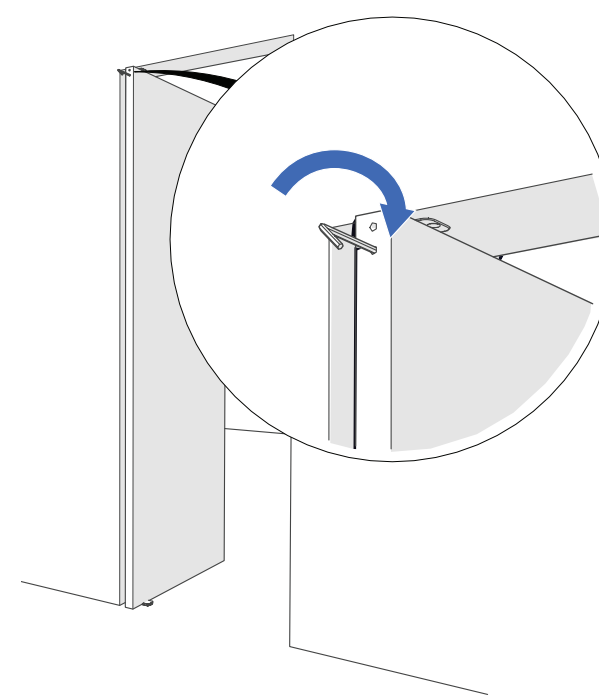

- 3 Extend the pivot with Allen key 5 or use the Hexagon Guide (page 12, item 6.2).

Top pivot 40 mm / 70 mm → Turn the key **8** times.

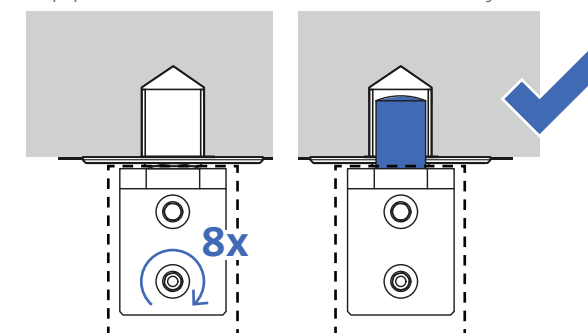

Top pivot cable grommet → Turn the key **16** times.

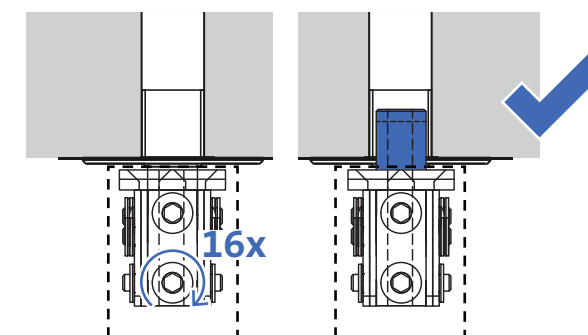

FINE-TUNING RADIAL POSITION*

- 1 Check the radial alignment of the door.

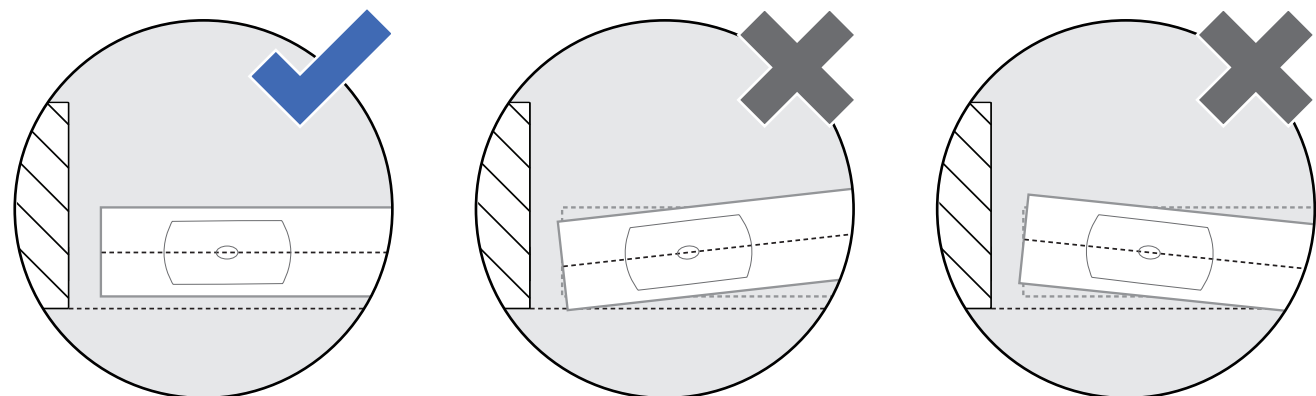

- 2 If the door is not properly aligned, unlock the floor plate with Allen key 3.
- 3 Rotate the floor plate until the door is aligned parallel to the wall.

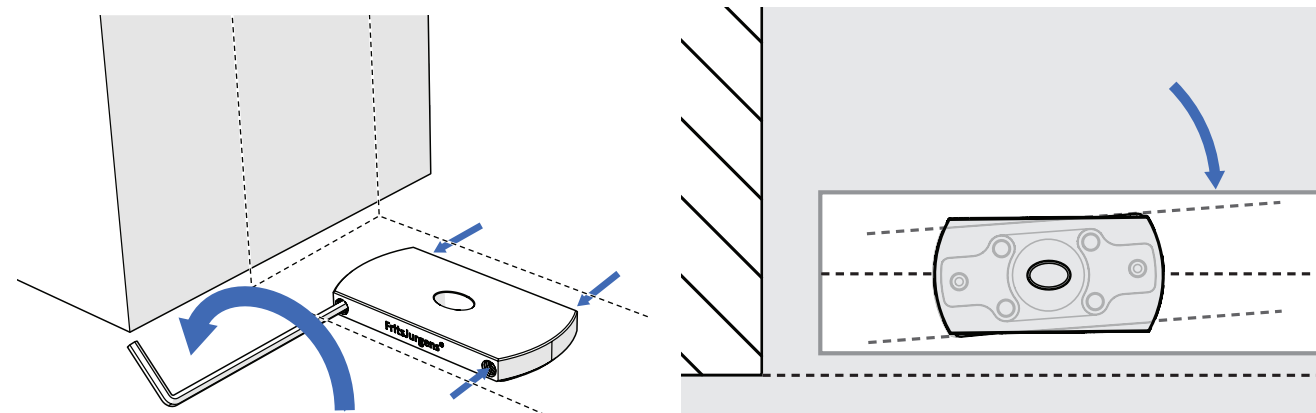

- 4 Lock the floor plate.

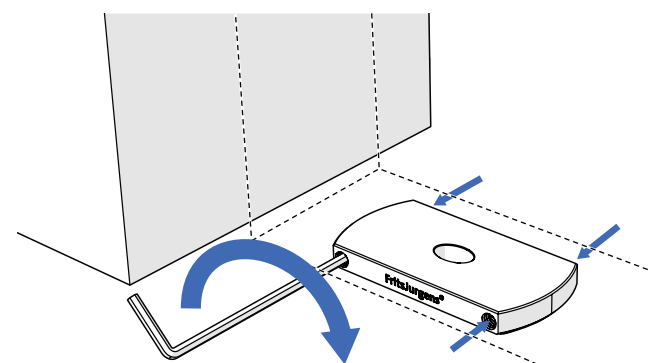

* Does not apply to floor plate Flush

FINE-TUNING THE CLOSING SEAM

- 1 Check if the door is aligned parallel to the ceiling and the wall.

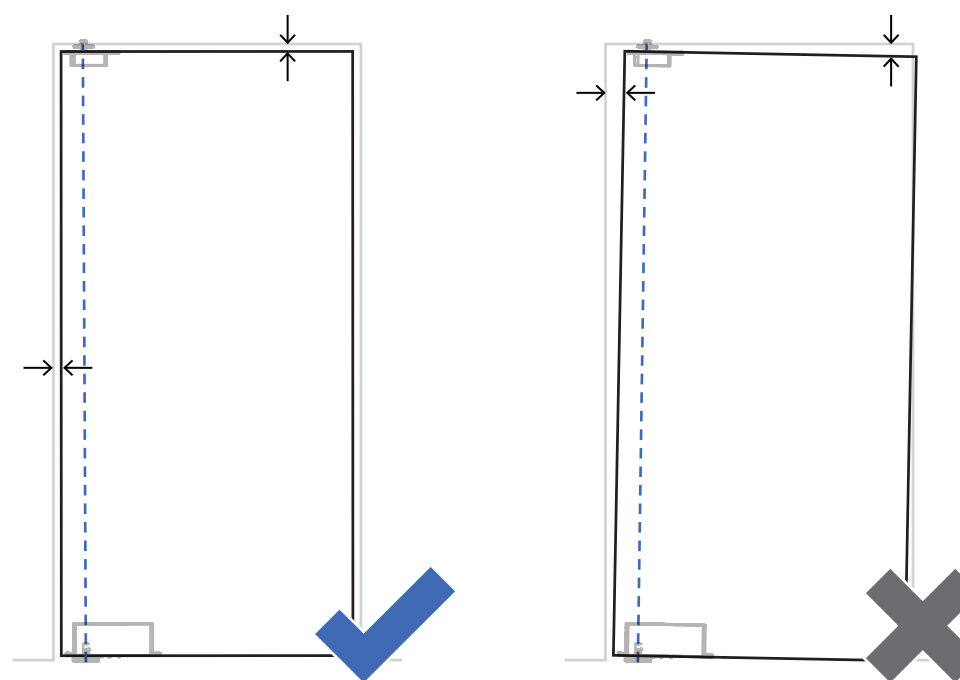

- 2 Open the door. Use Allen key 5 or the hexagon (page 12, item 6.2) until the door is aligned parallel to the ceiling and the wall.

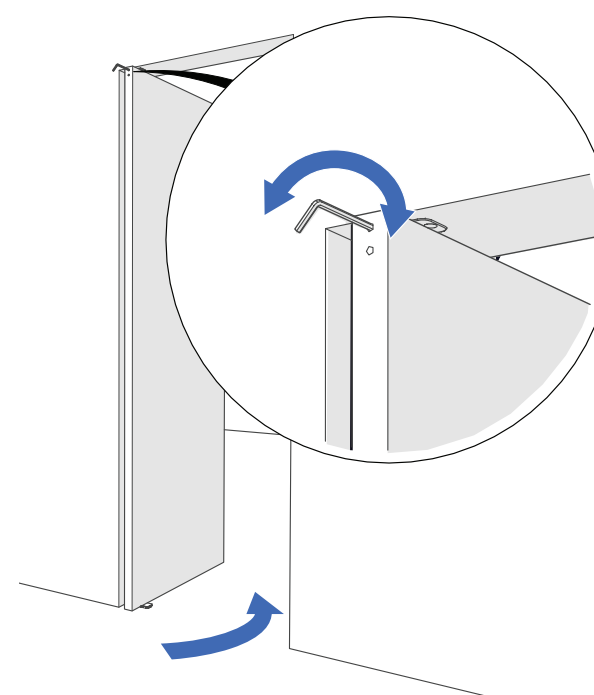

FINETUNING MOVEMENT

- 1 Use the reference sheet and the adjustment spanner to finetune the movement of the door.

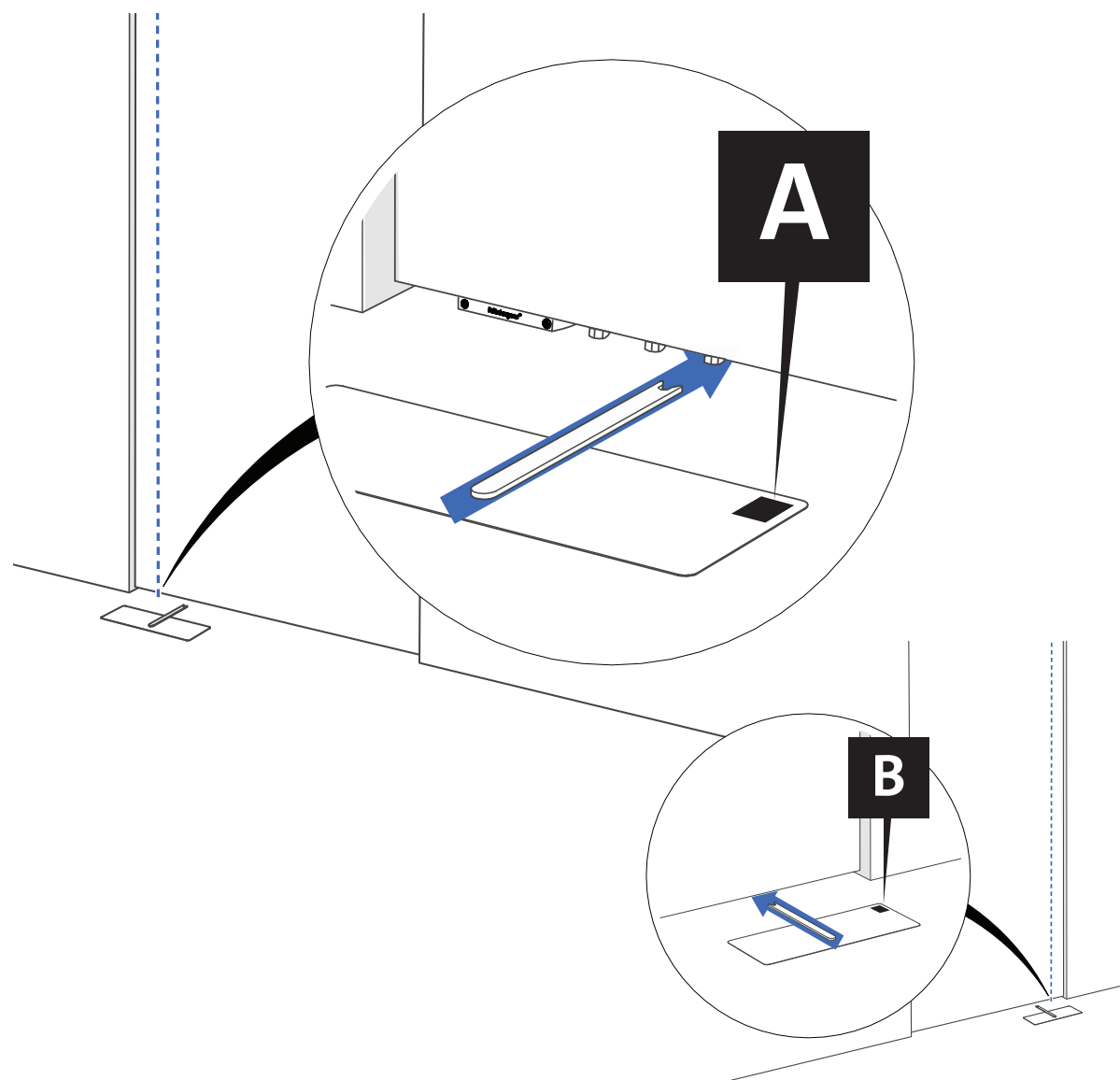

Use the front and bottom views to identify the adjustment screws.

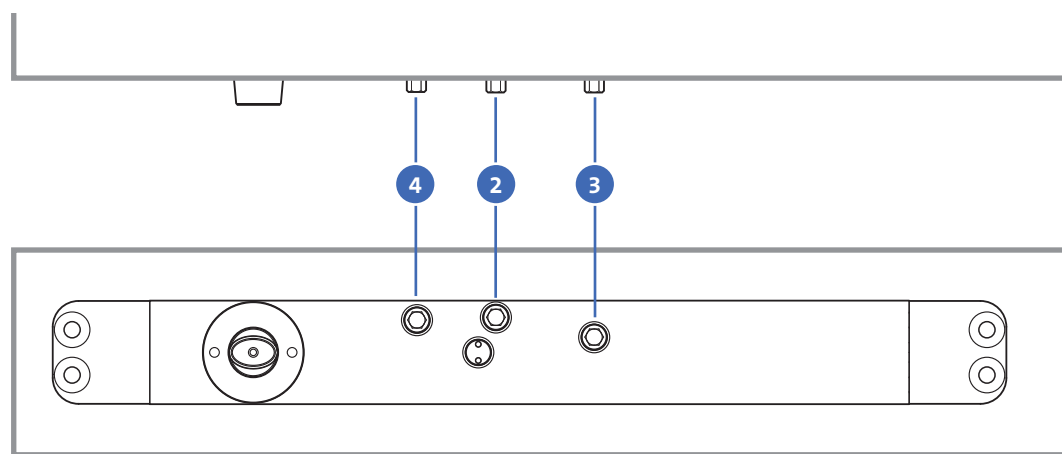

- 2 Adjust **Damper Control** to determine the door's opening speed (hydraulic backcheck).

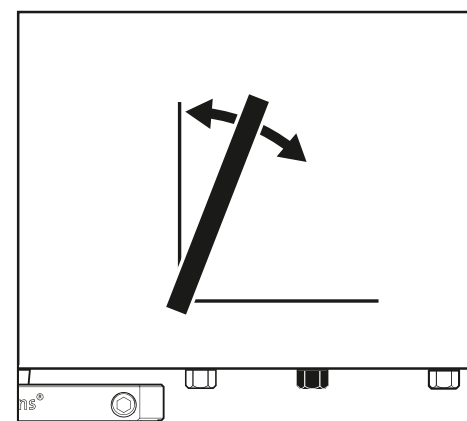

- 3 Adjust **30° Speed Control** to determine the door's speed in the last 30° of the closing movement.

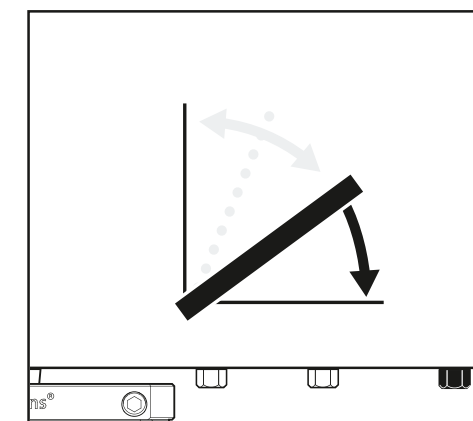

- 4 If your door has latching bolts, use **Latch Control** to make sure the door latches properly.

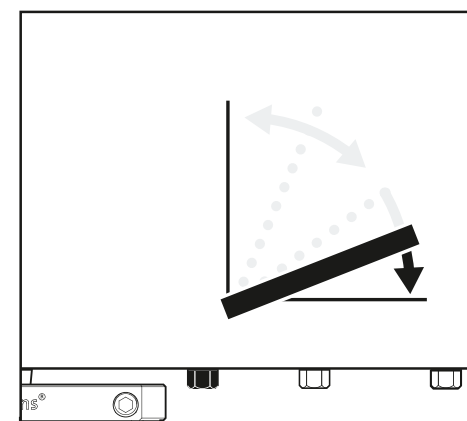

FritsJurgens®

FRITSJURGENS INTERNATIONAL

A. Einsteinlaan 1

9615 TE Kolham

The Netherlands

+31 598 343 410

info@fritsjurgens.com



BUY NOW : +1-888-636-1627



8 720681 618487 >